

Systemc[®] MINI

Vacuum Degassing Chamber

The Systemc MINI Vacuum Degassing Chamber was designed to be easy to prime, and is configured with a Systemc AF™ degassing membrane to provide maximum degassing capacity with the absolute minimum internal volume (<3% of PTFE designs with comparable degassing capacity).

- ▶ Ultra-high degassing efficiency
- ▶ Low volume
- ▶ Easy priming

Single Lumen Design

The Single lumen design ensures consistent degassing by avoiding variable flow issues that can be problematic in multi-lumen designs.

Customization Options

Custom degassing capacities, material choices, and metal free designs are available for OEM applications.

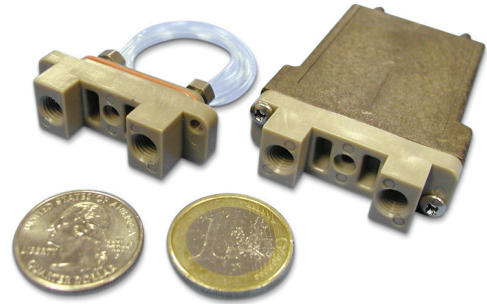

Degassing Efficiency: Residual air for Systemc Mini-chambers (percent dissolved air vs. flow rate).

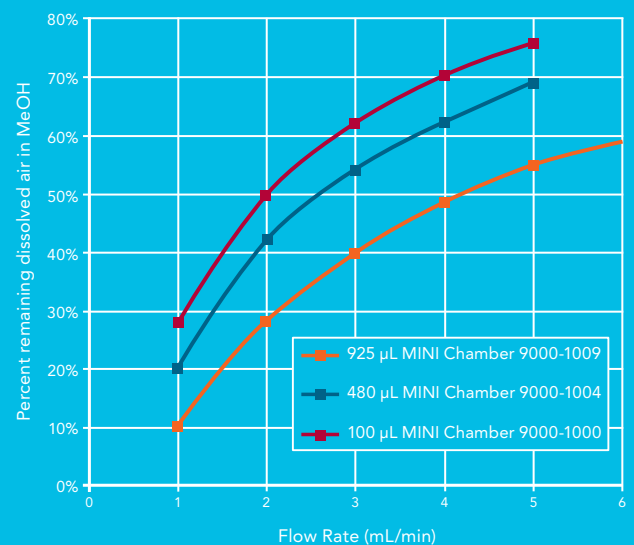

Plot shows remaining dissolved air in methanol using a selection of Systemc Mini-Chambers*. The range of chambers and specifications offered provide ample solutions for system designs.

* Water and Methanol mixtures between 30% and 70% methanol will outgas when more than 38% dissolved air remains in each of the solvents. Other water and organic mobile phases being mixed using a low pressure gradient system will undergo similar outgassing.



Phone: 212-204-0075
Email: info@pyvot.tech
Web: www.pyvot.tech

General Specifications

Degassing Channel Tubing:

- ▶ Systec AF™

Degassing Channel Pressure Rating:

- ▶ 70 PSIG (testing pressure)

Wetted Materials:

- ▶ Systec AF, PEEK, and Glass-filled PTFE or Glass-filled PPS and FEP depending on application

Vacuum Housing Material:

- ▶ Glass-filled PPS (Polyphenylene Sulfide)

Hardware Material:

- ▶ Stainless Steel or PPS

Liquid Connection:

- ▶ 1/4-28 UNF threaded flat-bottom port

Vacuum Connection:

- ▶ Barb-type fitting for 1.57mm (0.062") ID tubing

Overall Dimensions

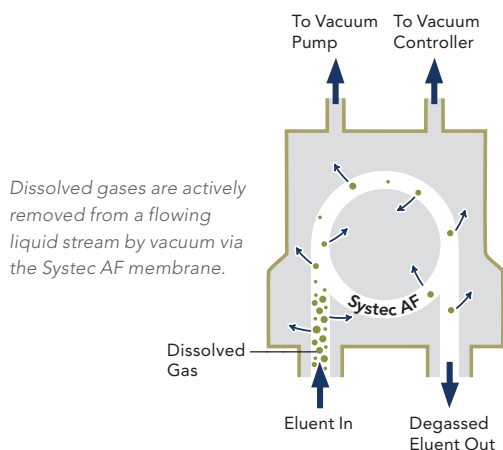
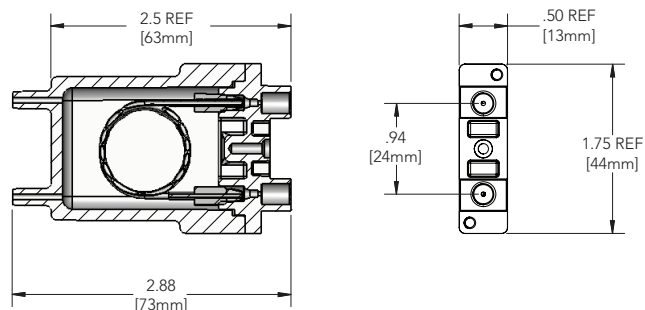

Dissolved gases are actively removed from a flowing liquid stream by vacuum via the Systec AF membrane.

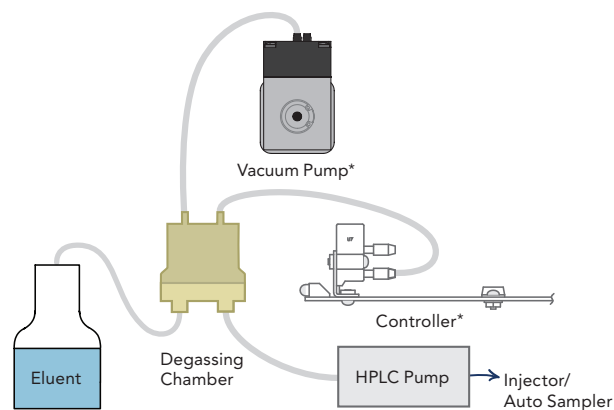

Typical Degasser Implementation

*See Systec® ZHCR® Vacuum Pump and Controller Product Data Sheet for more information.

Available Configurations^{A,B}

Systec Part Number	Application	Channel Volume (µL)	Max HPLC Gradient Flow Capability ^c (mL/min)	Pressure Drop ^D (kPa/mL/min)	Degassing Flow Path ID (mm/in)
9000-1000	Capillary	100	0.4	0.04	1.14/0.045
9000-1004	Analytical	480	2.0	0.18	1.14/0.045
9000-1006	Analytical	670	2.8	0.25	1.14/0.045
9000-1009	Analytical	925	4.0	0.36	1.14/0.045
9000-1184	Analytical/GPC	480	2.0	0.18	1.14/0.045

A. Custom configurations are available. Consult the factory for your specific application.

B. The standard MINI degassing chamber is not recommended for GPC applications (room temperature or heated), nor for use with HFIP (hexafluoroisopropanol).

We offer a special GPC "hardened" version. Please consult the factory for details.

C. The flow rates given are for a gradient mixture of 50/50 MeOH/H₂O, with a typical low pressure gradient mixing valve. Higher flow rates are possible with high pressure mixing.

D. Estimated tubing pressure per unit change in flow assuming laminar flow with a viscosity of 1.0 cP.



Phone: 212-204-0075
Email: info@pyvot.tech
Web: www.pyvot.tech

America Sales
Pyvot (previously Innovations United)
1040 1st Avenue
Suite #330
New York, NY 10022
Tel: 212-204-0075 ext. 1
Cell: 646-872-1539
Fax: 484-313-6368
Email: scott@pyvot.tech
Web: www.pyvot.tech