

Rheodyne® TitanHP™

High-Pressure Fluidic Valves

Reliability combined with unique engineering technology make Rheodyne TitanHP valves one of the most versatile and easy-to-use fluidic platforms. The TitanHP consists of an integrated driver/actuator and a removable liquid-end to provide a single, flexible space-saving design. Available for OEMs, these valves are rated up to 6000 psi (414 bar).

Principle of Operation

Rheodyne TitanHP valves use shear valve technology; the fluid inlet (stator) remains stationary as a grooved seal on the rotor surface rotates to change port connections. These valves are available in multiple position/port configurations and with different materials for compatibility.

Advanced Composites = Long Life Actuator

Highly inert and wear-resistant, the advanced composite polymers used extensively in the TitanHP valve actuator allow these valves to be actuated maintenance-free* for the life of the valve.

Rapid Replacement Pod™ Design for Easy Maintenance

The Rapid Replacement Pod design of the TitanHP liquid-end lends itself to two easy methods of field maintenance. The entire Pod can be purchased separately and replaced as a unit, with virtually no instrument downtime for repair. Or, genuine Rheodyne RheBuild® Kits are available for replacement of just the liquid-end rotor seal component.

Extended Valve Life

The DuraLife® wear surfaces available on the TitanHP valve help reduce frequent replacement of wear components. That means longer in-service cycles and lower field service costs. Biocompatible wear surfaces are also available.

*Within established ranges.



Available with Integrated Driver Board

An optional driver board integrates with the TitanHP valves to provide the added functionality of motor drive and valve control without significantly affecting the remarkably small footprint of this multi-position valve. OEM customers only need to provide the digital control signals and 24V DC power in order to achieve random access actuation and position feedback. All valves may be controlled by BCD, I²C, UART, Pulse or Dual Pulse standards; two-position valves may also be controlled with level logic. In the case where multiple devices need to be controlled, I²C communication allows up to 128 devices to be connected to a single instrument. The default configuration is level logic for the two-position and BCD for the multi-position valves.

Eliminating customer development of board and firmware means shorter product development cycles and reduced time-to-market.



Phone: 212-204-0075
Email: info@pyvot.tech
Web: www.pyvot.tech

Eastern Plastics | Gast | Innovadyne | Ismatec | Isolation Technologies | Jun-Air
Micropump | Rheodyne | Sapphire Engineering | Semrock | Systec | Trebor | Upchurch Scientific

TitanHP™

2-Position, 6-Port TitanHP with PCB shown.
 Dimensions given in inches and [millimeters]

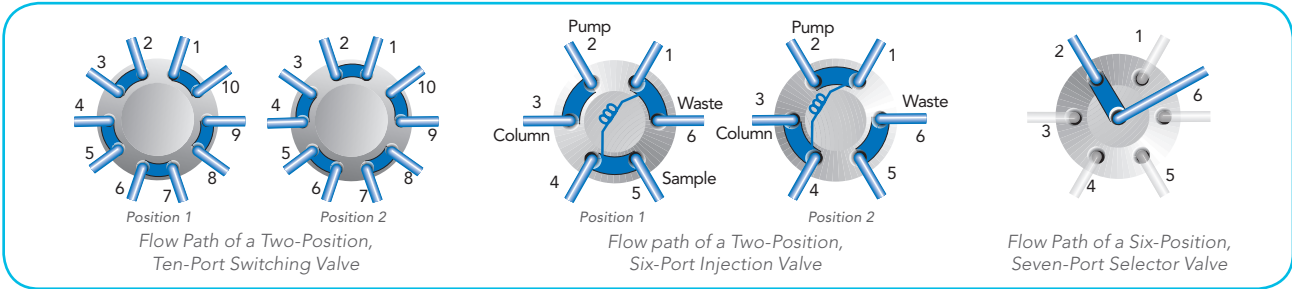
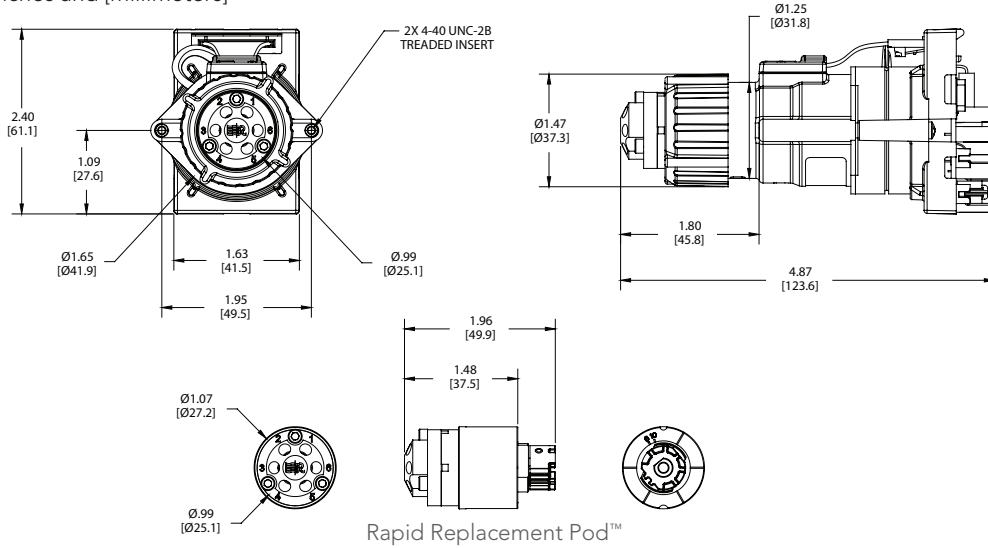

TitanHP Products

Valves with PCB	Valves without PCB	Description	Rapid Replacement Pods™:	
MHP7900-500-1	MHP7900-000	2-Position, 6-Port Injector, DuraLife®	PD7900	2/6 Injector, DuraLife
MHP9900-500-1	MHP9900-000	2-Position, 6-Port Injector, PEEK™	PD9900	2/6 Injector, PEEK
MHP7960-500-1	MHP7960-000	2-Position, 10-Port Switching Valve, DuraLife	PD7960	2/10 Switching Valve, DuraLife
MHP9960-500-1	MHP9960-000	2-Position, 10-Port Switching Valve, PEEK	PD9960	2/10 Switching Valve, PEEK
MHP7920-500-1	MHP7920-000	2-Position, 6-Port Vertical Port Injector, DuraLife	PD7920	2/6 Vertical Port Injector, DuraLife
MHP7970-500-4	MHP7970-000	6-Position, 7-Port Selector, DuraLife II	PD7970	6/7 Selector, DuraLife II
MHP7980-500-1	MHP7980-000	2-Position, 6-Port Nano Injector, DuraLife II	PD7980	2/6 Nano Injector, DuraLife II
MHP7986-500-1	MHP7986-000	2-Position, 10-Port Nano Switching Valve, DuraLife II	PD7986	2/10 Nano Switching Valve, DuraLife II

For additional High Pressure Valve options see the TitanHT Product Sheet



Phone: 212-204-0075
 Email: info@pyvot.tech
 Web: www.pyvot.tech