

Rheodyne® TitanHT™

High-Torque Fluidic Valves

The Rheodyne TitanHT valves provide OEMs with a single solution for nano- to prep-scale applications in the next generation of very-high-pressure valve technology. Designed for the high torque demands of the evolving HPLC market, these versatile, multi-position valves are rated up to 15,000 psi (1034 bar).

High Torque, High Pressure Performance

The TitanHT is designed for use in high pressure and very-high-pressure HPLC applications. Using a unique liquid-end (Pod) design, the actuator can be separated from the Pod providing flow-path flexibility to accommodate new applications, or next generation HPLC technology.

Principle of Operation

The Rheodyne TitanHT uses shear valve technology; the fluid inlet (stator) remains stationary as a grooved seal on the rotor surface rotates to change port connections. These valves are available in multiple position/port configurations and with different materials for compatibility.

Rapid Replacement Pod™

Design for Easy Maintenance

The Rapid Replacement Pod design of the TitanHT liquid-end lends itself to two easy methods of field maintenance. The Pod can be purchased separately and replaced as a unit, allowing virtually no instrument downtime for repair. Or, genuine Rheodyne RheBuild® Kits are available for replacement of just the rotor seal component.

Advanced Composites = Long Life Actuator

Highly inert and wear-resistant, the advanced composite polymers used extensively in the TitanHT valve actuator allow these valves to be actuated maintenance-free* for the life of the valve.

*Within established ranges.



Make-Before-Break (MBB®)

Rheodyne valves' unique, patented MBB architecture design provide uninterrupted flow when switching between LOAD and INJECT positions. MBB greatly reduces transient pressure shocks and is beneficial for flow-sensitive detectors, fragile columns, and pumps. This Make-Before-Break feature extends the life of your column.†

Available Driver Board

The specially designed PCB for motor drive and valve control integrates easily into your new instrument. OEM customers only need to provide the digital control signals and 24V DC power in order to achieve random access actuation and position feedback. All valves may be controlled by BCD, I²C, UART, Pulse or Dual Pulse standards; two-position valves may also be controlled with level logic. In the case where multiple devices need to be controlled, I²C communication allows up to 128 devices to be connected to a single instrument. The default configuration is level logic for the two-position and BCD for the multi-position valves.

Eliminating customer development of board and firmware means shorter product development cycles and reduced time-to-market.

† Available on some TitanHT valves.



Phone: 212-204-0075
Email: info@pyvot.tech
Web: www.pyvot.tech

Eastern Plastics | Gast | Innovadyne | Ismatec | Isolation Technologies | Jun-Air
Micropump | Rheodyne | Sapphire Engineering | Semrock | Systec | Trebor | Upchurch Scientific

TitanHT™

2-Position, 6-Port TitanHT shown.
Dimensions given in inches and [millimeters]

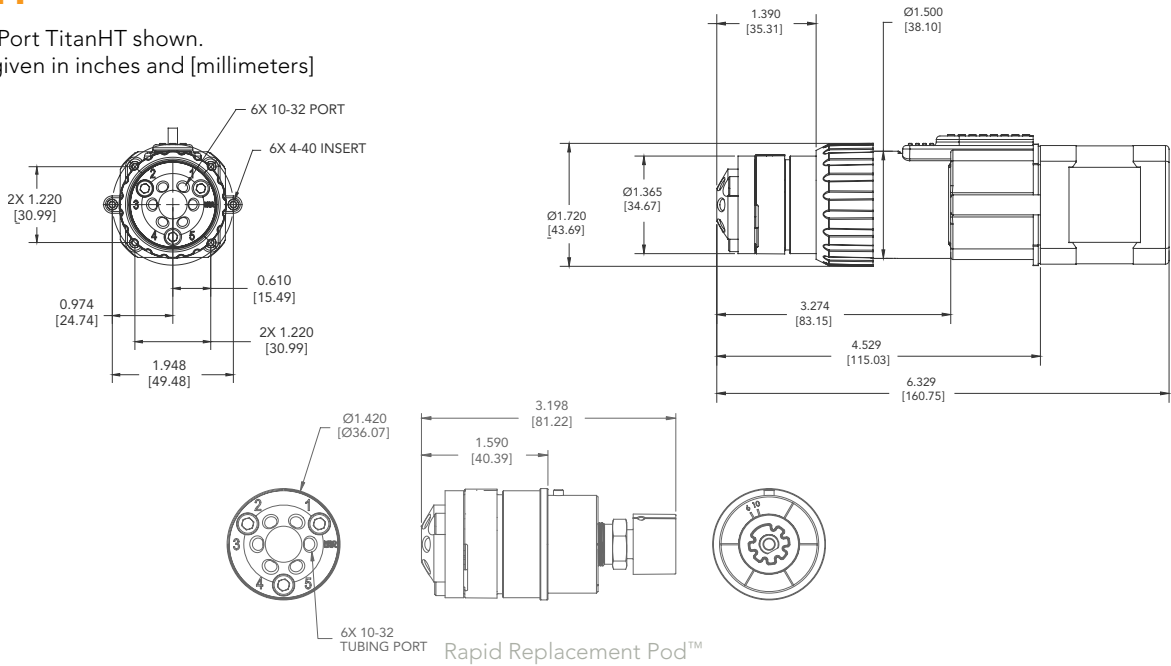

TitanHT Products

Very High Pressure Valves: (15,000 psi)

* HT715-000	2-Position, 6-Port Injector, UltraLife™
HT715-102	2-Position, 10-Port Switching Valve, UltraLife
HT715-105	6-Position, 7-Port Selector, UltraLife
* HT715-121	2-Position, 6-Port Vertical Injector, UltraLife

Optional Driver Board:

8382-108
8382-104
8382-103
8382-106

Rapid Replacement Pods™:

PD715-000	2-Position, 6-Port Injector, UltraLife
PD715-102	2-Position, 10-Port Switching Valve, UltraLife
PD715-105	6-Position, 7-Port Selector, UltraLife
PD715-121	2-Position, 6-Port Vertical Injector, UltraLife

High Pressure Valves: (≤ 6000 psi)

HT700-107	10-Position, 11-Port Selector, Stainless Steel (5000 psi)	8382-102	PD700-107	10-Position, 11-Port Selector, Stainless Steel
HT750-107	10-Position, 11-Port Selector, PEEK™ (5000 psi)	8382-102	PD750-107	10-Position, 11-Port Selector, PEEK
HT704-100	8-Position, 4-Port Diverter, UltraLife™ (3000 psi)	8382-107	PD704-100	8-Position, 4-Port Diverter, UltraLife
HT650-100-4	8-Position, 17-Port Stream Selector w/PCB, PEEK (100 psi)	8382-107	PD650-100	8-Position, 17-Port Stream Selector, PEEK
HT706-100	6-Position, 7-Port Selector, UltraLife (3000 psi)	8382-103	PD706-100	6-Position, 7-Port Selector, UltraLife
HT703-100	3-Position, 7-Port Injector w/Purge, Stainless Steel (5000 psi)	8382-103	PD703-100	3-Position, 7-Port Injector w/Purge, Stainless Steel
HT753-100	3-Position, 7-Port Injector w/Purge, PEEK (5000 psi)	8382-103	PD753-100	3-Position, 7-Port Injector w/Purge, PEEK
HT700-112	2-Position, 6-Port, Semi Prep Injector, Stainless Steel (3000 psi)	8382-105	PD700-112	2-Position, 6-Port Semi Prep Injector, Stainless Steel
HT700-113	2-Position, 6-Port, Semi Prep Injector, DuraLife® (6000 psi)	8382-105	PD700-113	2-Position, 6-Port Semi Prep Injector, DuraLife
HT750-112	2-Position, 6-Port, Semi Prep Injector, PEEK (3000 psi)	8382-105	PD750-112	2-Position, 6-Port Semi Prep Injector, PEEK

*Valve containing with the Make-Before-Break feature
For additional High Pressure Valve options see the TitanHP Product Sheet

TitanHT™, UltraLife™, and Rapid Replacement Pod™ are trademarks of IDEX Health & Science LLC.
DuraLife®, MBB®, RheoBuild®, and Rheodyne® are registered trademarks of IDEX Health & Science LLC.
PEEK™ polymer is a trademark of Victrex plc.
© 2009 IDEX Health & Science LLC

R3:500-02/2009



Phone 212-204-0075
Email info@pyvot.tech
Web www.pyvot.tech