

Rheodyne MX Series II Modules

Automated Valve Solutions

Rheodyne's MX Series II automated fluidic valves provide productivity enhancing solutions for the demands of today's analytical methods. Combine the MX Series II Valves with your current instrument to support complex fluid switching and sample injection needs.

Increase Laboratory Productivity

The MX Series II Modules are available in a variety of flow paths including options for Nano, Analytical, Semi-prep, Low Pressure and Fast Chromatography applications up to 15,000 psi (1000 bar). These modular valves provide reliable automation, increasing laboratory productivity and saving valuable resource time.

Outstanding Performance

The MX Series II Modules feature the proven performance of the Rheodyne Titan series of valves. These modules feature Rheodyne's proprietary DuraLife™ and UltraLife™ materials for extended wear component lifetime. For even better performance choose our low-dispersion MXP modules.



Easy to Use

These modules are ready for remote operation via USB connection or by simple contact closure. The MX Series II Modules also offer the flexibility of simple manual operation by push-button front control with LED display.

Stand-Alone Capability

MX Series II modular valves can be used as a stand-alone unit or in combination with other devices such as a syringe or peristaltic pump to accommodate unique applications in sample analysis such as flow-injection, flow cytometry and process monitoring in addition to complex chromatography applications.



Phone: 212-204-0075
Email: info@pyvot.tech
Web: www.pyvot.tech

Intelligent Solutions for Life™
Fluidics | Optics | Consumables | Assemblies

MX Series II Modules

Dimensions given in inches and millimeters [in brackets].

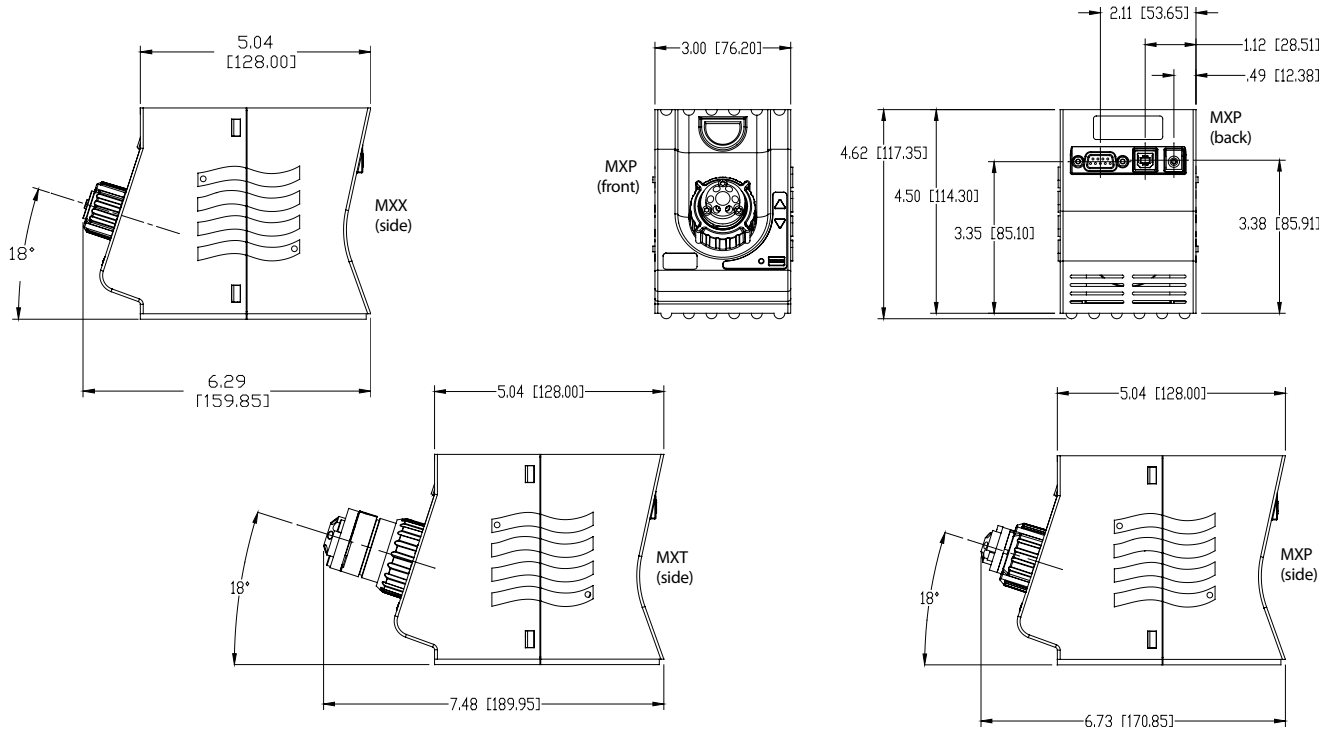

MX Series II Modules Available Include:

MXT for Fast Chromatography Applications, up to 15,000 psi (1000 bar)

Part Number	Description	Material	Stator Passages
MXT715-000	2-position 6-port Switching Valve	Stainless Steel UltraLife™ *	0.011"
MXT715-105	6-position 7-port Selector Valve	Stainless Steel UltraLife	0.011"

MXP for High Pressure Applications, up to 6000 psi (400 bar)

Part Number	Description	Material	Stator Passages
MXP7900-000	2-position 6-port Switching Valve	Stainless Steel DuraLife™ *	0.012"
MXP9900-000	2-position 6-port Switching Valve	PEEK™	0.012"
MXP7960-000	2-position 10-port Switching Valve	Stainless Steel DuraLife	0.010"
MXP7970-000	6-position 7-port Selection Valve	Stainless Steel DuraLife	0.012"
MXP9960-000	2-position 10-port Switching Valve	PEEK	0.010"
MXP7980-000	2-position 6-port Nano Switching Valve	Titanium DuraLifell™ *	0.004"
MXP7986-000	2-position 10-port Nano Switching Valve	Titanium DuraLifell	0.004"

MXX for Low Pressure Applications, up to 125 psi (9 bar)

Part Number	Description	Material	Stator Passages
MXX777-601	2-position 6-port Switching Valve	RPC-7**	0.016"
MXX777-603	2-position Double Three-way Valve	RPC-7	0.016"
MXX777-605	6-position 7-port Selection Valve	RPC-7	0.040"
MXX777-612	2-position 6-port Switching Valve	RPC-7	0.060"
MXX777-616	6-position 7-port Switching Valve	RPC-7	0.060"
MXX778-605	10-position 11-port Selection Valve	RPC-7	0.060"

* Proprietary Coating Materials

**RPC-7: Proprietary Polymer Combination



Phone: 212-204-0075
Email: info@pyvot.tech
Web: www.pyvot.tech